

**EUROMAP 81.2**

**Electrical Interface  
for Safety Signals –  
Part 2: Usage of two separate safety devices**

**Version 1.0, 24 May 2024**  
8 pages

This recommendation was prepared by the Technical Commission of EUROMAP.

<b>Contents</b>		<b>Page</b>
<b>1</b>	<b>Scope and Application</b> .....	<b>3</b>
<b>2</b>	<b>Description</b> .....	<b>3</b>
2.1	Plug and socket outlets.....	3
2.2	Contact specification .....	4
2.3	Performance levels of signals .....	4
2.4	Signal delay.....	4
2.5	Plug contact assignment.....	5
<b>3</b>	<b>Schematic drawing of the interface</b> .....	<b>6</b>
<b>4</b>	<b>Sources of supply</b> .....	<b>7</b>

# 1 Scope and Application

This EUROMAP recommendation defines the connection between plastics and rubber machines for the exchange of safety signals. This is intended to provide interchangeability.

This recommendation describes an interface used for safety signals only. This can be used, when non-safety relevant signals are exchanged via other interfaces (e.g. on the basis of OPC UA).

This part of the recommendation is used, when two safety devices are regarded separately (e.g. safety devices for front and rear side of machine). If only one safety device is present or one signal for multiple safety guards is sufficient part 1 shall be used.

# 2 Description

The interface connects two machines A and B with the following requirements:

- Both machines are equipped with emergency stop devices.
- Actuation of the emergency stop device of one machine causes also emergency stop of the other.
- Machine A is equipped with two separate safety devices (e.g. safety guards, footboard safety, etc.) that allow dangerous movements of machine B.

Example: machine A: injection moulding machine, machine B: robot

## 2.1 Plug and socket outlets

The connection between the machines is achieved by the plugs specified below.

Arrangements of pins and sockets viewed from the mating side (opposite the wiring side)

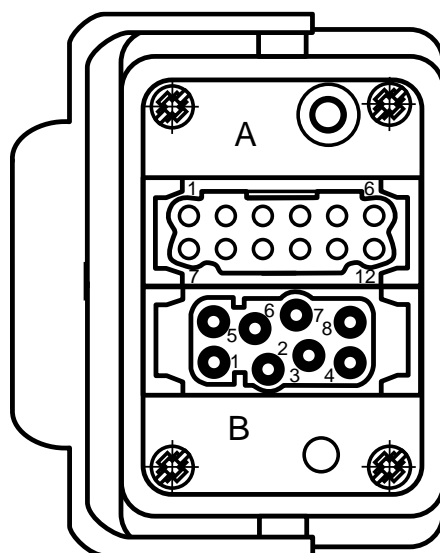

○ = pin

Figure 1: Plug on machine A

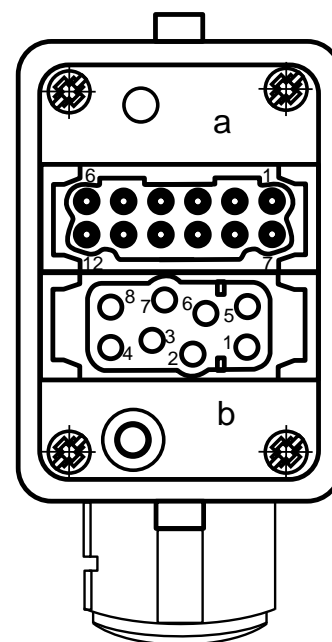

● = socket

Figure 2: Plug on machine B

## 2.2 Contact specification

- The voltages of the signals must not exceed 50 V DC.
- A current of at least 6 mA must be maintained during signalling.
- The maximum current is 2 A.

## 2.3 Performance levels of signals

- The signals from the safety devices shall be in accordance with  $PL_r = d$  (EN ISO 13849-1) or higher.
- The signals from the emergency stops shall be in accordance with  $PL_r = d$  (EN ISO 13849-1) or higher.

A higher Performance Level might be required due to a risk assessment (e.g. by the integrator)

## 2.4 Signal delay

Safety signals transmitted via two channels shall have a maximum delay  $<0,5$  s between channel 1 signal and channel 2 signal. This is to be applied to "Emergency stop of machine" and "Safety devices of machine".

## 2.5 Plug contact assignment

**Table 1: Plug on machine A  
Signals from machine A to machine B**

Contact No. see fig. 1	Signal designation	Description
A1/A7	Emergency stop of machine A channel 1	The switch contact shall be open when emergency stop device of machine A is being actuated. Opening the switch contact causes emergency stop of machine B.
A2/A8	Safety device 1 of machine A channel 1	The switch contact is closed when safety device 1 (e.g. safety guard, footboard safety, etc.) on machine A is operative so that dangerous movements of machine B are possible. The signal is active in any operation mode.
A3/A9	Safety device 2 of machine A channel 1	The switch contact is closed when safety device 2 (e.g. safety guards, footboard safety, etc.) on machine A is operative so that dangerous movements of machine B are possible. The signal is active in any operation mode.
A4/A10	Emergency stop of machine A channel 2	The switch contact shall be open when emergency stop device of machine A is being actuated. Opening the switch contact causes emergency stop of machine B.
A5/A11	Safety device 1 of machine A channel 2	The switch contact is closed when safety device 1 (e.g. safety guards, footboard safety, etc.) on machine A is operative so that dangerous movements of machine B are possible. The signal is active in any operation mode.
A6/A12	Safety device 2 of machine A channel 2	The switch contact is closed when safety device 2 (e.g. safety guards, footboard safety, etc.) on machine A is operative so that dangerous movements of machine B are possible. The signal is active in any operation mode.

**Table 2: Plug on machine A  
Signals from machine B to machine A**

Contact No. see fig. 1	Signal designation	Description
B1/B5	Emergency stop of machine B channel 1	The switch contact shall be open when the emergency stop device of machine B is being actuated. The switch contact opening causes emergency stop of machine A. The switch contact shall be operative if machine B is switched off. It is recommended that the switch contact is operative when machine B is unselected.
B3/B7	Emergency stop of machine B channel 2	The switch contact shall be open when the emergency stop device of machine B is being actuated. The switch contact opening causes emergency stop of machine A. The switch contact shall be operative if machine B is switched off. It is recommended that the switch contact is operative when machine B is unselected.
B2/B6	Machine B unmounted	The contact shall be closed when machine B is unmounted and a blind plug is used on machine A. In this case, the emergency stop signals B1/B5 and B3/B7 have to be bridged in the blind plug. The schematic drawing of the blind plug is shown in Figure 4. The contact shall be open when machine B is connected.
B4/B8	Spare	Reserved for future use by EUROMAP

### 3 Schematic drawing of the interface

Figure 3 shows the schematic drawing of the interface with the emergency stop device not actuated and the safety devices not operative.

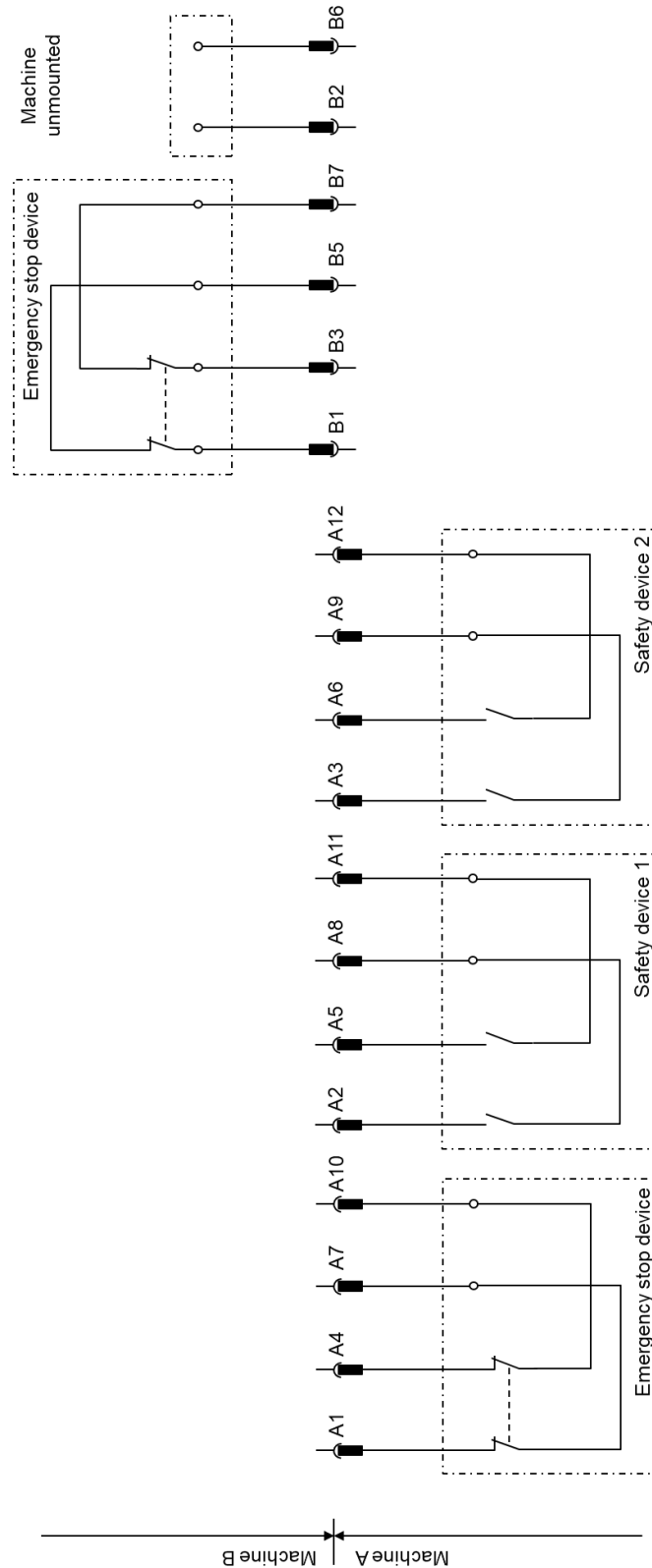
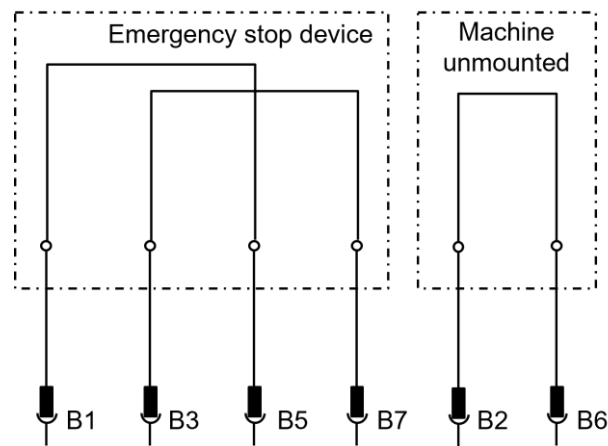

Figure 3: Schematic drawing of the interface

Figure 4 shows the schematic drawing of the blind plug.



**Figure 4: Schematic drawing of the blind plug**

## 4 Sources of supply

A list of suppliers for the plugs described in clause 2 can be downloaded from the following website:  
<http://www.euromap.org/technical-issues/technical-recommendations>

## **EUROMAP**

Europäisches Komitee der Hersteller von Kunststoff- und Gummi-  
maschinen

European Committee of Machinery Manufacturers for the Plastics  
and Rubber Industries

Comité Européen des Constructeurs de Machines pour Plastiques  
et Caoutchouc

Comitato Europeo Costruttori Macchine per Materie Plastiche e  
Gomma

*See you again*

*<http://www.euromap.org>*

**Copyright by EUROMAP**